

# ARCTIS 238-1 GS

Diepvriestkast  
Freezer  
Congelatore

Gebruiksaanwijzing  
Operating Instruction  
Libretto d'istruzione

AEG Hausgeräte GmbH  
Postfach 1036  
D-90327 Nürnberg

<http://www.aeg.hausgeraete.de>

© Copyright by AEG  
2222 359-32 09/04

Wijzigingen voorbehouden  
Subject to change without notice  
Con riserva di modifiche

Mediante ciò si evita che si possano chiudere dentro dei bambini che giocano (pericolo di soffocamento!) oppure che possano trovarsi in altre situazioni pericolose per la vita.

- Molto spesso i bambini non possono rendersi conto dei pericoli a cui sono esposti durante il maneggio con gli apparecchi domestici. Pertanto è necessario prendere degli idonei provvedimenti di salvaguardia evitando inoltre di lasciar giocare i bambini con tali apparecchi!!

### Nel servizio quotidiano

- I contenitori di gas infiammabili oppure liquidi mediante l'effetto del freddo possono perdere la propria ermeticità. Pericolo di esplosione! Non immagazzinare mai dei contenitori con sostanze infiammabili, come p.es. bombole spray, accendini e cartucce di rifornimento, ecc. nell'apparecchio.
- Le bottiglie e le lattine non devono essere collocate nella cella di congelamento. Queste possono scoppiare non appena si congela il contenuto, mentre i liquidi contenenti anidride carbonica possono addirittura esplodere! Non collocare mai della limonata, succhi, birra, vino, spumante, ecc. Ad eccezione dei superalcolici.
- Non ingoiare i gelati oppure i cubetti di ghiaccio appena estratti dalla cella di congelamento. Il gelato oppure ghiaccio molto freddo si può congelare alla lingua o alle labbra e causare quindi delle ferite.
- Non toccare i prodotti congelati con le mani bagnate. Le mani si potrebbero congelare sul prodotto.
- Non impiegare mai dei piccoli elettrodomestici (p.es. macchine elettriche da gelato, mescolatori, ecc.) nell'apparecchio.
- Prima di eseguire i lavori di pulizia, è necessario disinserire l'apparecchio, estrarre la spina oppure disinserire rispett. svitare il fusibile dell'abitazione.
- Estrarre la spina di rete dalla presa tirando sempre dalla parte della spina, mai dal cavo.

### Nel caso di un disturbo

- Se nell'apparecchio dovesse verificarsi dei disturbi, si prega di leggere le istruzioni del capitolo "Che cosa fare, se...". Nel caso non siano sufficienti le avvertenze riportate, si prega di non eseguire ulteriori lavori autonomi di riparazione
- Gli apparecchi devono essere riparati esclusivamente da persone specializzate. Mediante le riparazioni non appropriate possono crearsi dei notevoli pericoli. Nella necessità di una riparazione, si prega di rivolgersi al proprio fornitore oppure presso il nostro servizio di assistenza.

### Dear customer,

Before placing your new refrigerator/freezer into operation please read these operating instructions carefully. They contain important information for safe use, for installation and for care of the appliance.

Please keep these operating instructions for future reference. Pass them on to possible new owners of the appliance.



Notes which are important for your safety or for the proper functioning of the appliance are stressed with a warning triangle and/or with signal words (Warning!, Caution!, Attention!). Please observe the following carefully.



Supplementary information regarding operation and practical applications of the appliance appear after this symbol.



Tips and notes concerning economical and environmentally sound use of the appliance are marked with the cloverleaf.

The operating instructions contain instructions for the correction of possible malfunctions by the user in the section "What to do if ...". If these instructions should not be sufficient, our customer service department is always available to you.

Printed on paper manufactured with environmentally sound processes.  
who thinks ecologically acts accordingly ...

## Contents

Safety .....	21
Disposal .....	23
Appliance Packaging Information .....	23
Disposal of old Appliances .....	23
Remove transport safeguard .....	23
Installation .....	24
Installation Location .....	24
Your appliance needs air .....	25
Rear spacers .....	25
Rehinging the door .....	25
Electrical Connection .....	26
Prior to Initial Start-Up .....	27
Operating and indicator panel .....	27
Starting up and temperature regulation .....	28
Freezing and storing frozen food .....	29
Preparation of Ice Cubes .....	30
Ice Pack .....	30
Defrosting .....	30
Cleaning and Care .....	31
Switching off the appliance .....	32
Energy Saving Tips .....	32
What to do if .....	33
Correcting Malfunctions .....	33
Regulation, Standard and Guidesline .....	34

## Sicurezza

La sicurezza dei nostri apparecchi è conforme ai regolamenti approvati della tecnica ed alla legge di sicurezza degli apparecchi. Nonostante ciò, riteniamo di doverVi facilitare la presa di confidenza con le seguenti avvertenze:

### Impiego conforme alla scopo previsto

- L'apparecchio è stato stabilito per l'uso domestico. È adatto per congelare ed la surgelazione di prodotti alimentari nonché per la preparazione di gelati.
- Per motivi di sicurezza non è consentito in nessun caso apportare delle modifiche o trasformazioni.
- Nel caso si voglia impiegare l'apparecchio refrigerante per scopi differenti dal congelamento di prodotti alimentari, si prega di osservare le disposizioni di legge vigenti per il Vostro settore.

### Prima della prima messa in servizio

- Verificare l'apparecchio su eventuali danni causati dal trasporto. Non collegare in nessun caso un apparecchio danneggiato! In caso di danni rivolgersi al fornitore.

### Sostanza refrigerante

L'apparecchio contiene nel circuito refrigerante un gas naturale denominato Isobutano (R600a), avente una elevata tolleranza per l'ambiente, il quale è tuttavia infiammabile.

- Osservare durante il trasporto e l'installazione dell'apparecchio che non venga danneggiato alcun elemento del circuito refrigerante.
- In caso di danneggiamenti al circuito refrigerante:
  - evitare assolutamente fiamme libere e fonti incendianti;
  - provvedere ad una buona aerazione.

### Sicurezza dei bambini

- I pezzi di imballaggio (p.es. foglie, polistirolo) possono essere pericolosi per i bambini. Pericolo di soffocamento! Mantenere il materiale di imballaggio al di fuori della portata dei bambini!
- Gli apparecchi che non vengono più utilizzati devono essere resi inutilizzabili prima dello smaltimento. Estrarre la spina di rete, spezzare il cavo di rete, rimuovere oppure distruggere le eventuali chiusure di bloccaggio.

## Indice

Sicurezza.....	37
Smaltimento.....	39
Informazione sull'imballaggio dell'apparecchio.....	39
Smaltimento di apparecchi vecchi.....	39
Rimuovere la sicura del trasporto.....	39
Installazione.....	40
Luogo di installazione.....	40
Aereazione.....	41
Distanziali posteriori.....	41
Reversibilità della porta.....	41
Collegamento elettrico.....	42
Prima della messa in servizio.....	43
Pannello di controllo.....	43
Messa in servizio e regolazione della temperatura.....	44
Congelazione e surgelazione.....	45
Calendario di congelamento.....	46
Cubetti ghiaccio.....	47
Sbrinamento e Pulizia.....	47
Spegnimento dell'apparecchio.....	49
Consigli per il risparmio energetico.....	49
Che cosa fare, se.....	50
Rimedio in caso di disturbi.....	50
Servizio di assistenza.....	52
Disposizioni, Norme, Direttive.....	52

## Safety

The safety aspects of our refrigerators/freezers comply with accepted technical standards and the German Appliance Safety Law. Nevertheless, we consider it our obligation to make you aware of the following safety information:

### Intended use

- The refrigerator is intended for use in the home. It is suitable for the freezing and storing of frozen food, as well as for making ice. If the appliance is used for purposes other than those intended or used incorrectly, no liability can be accepted by the manufacturer for any damage that may be caused.
- Alterations or changes to the freezer are not permitted for reasons of safety.
- If you use the appliance in a commercial application or for purposes other than the freezing or frozen storage of foods, please observe all valid legal regulations for your application.

### Prior to initial start-up

- Check the appliance for transport damage. Under no circumstance should a damaged appliance be plugged in! In the event of damage, please contact the vendor.

### Refrigerant

The refrigerant isobutane (R600a) is contained within the refrigerant circuit of the appliance, a natural gas with a high level of environmental compatibility, which is nevertheless flammable.

- During transportation and installation of the appliance, be certain that none of the components of the refrigerant circuit become damaged.
- If the refrigerant circuit should become damaged:
  - avoid open flames and sources of ignition;
  - thoroughly ventilate the room in which the appliance is situated.

### Safety of children

- Packaging (e.g. wraps, polystyrene) can be dangerous for children. There is a risk of suffocation! Keep packaging material away from children!
- Please make old appliances unusable prior to disposal. Pull out the mains plug, cut off the mains cable, break or remove spring or boltcatches, if fitted. By doing this you ensure that children cannot lock themselves in the

fridge when playing (there is risk of suffocation!) or get themselves into other dangerous situations.

- Often children cannot recognise the hazards present in household appliances. It is therefore important that you ensure adequate supervision and never let children play with the appliance!

## Daily Operation

- Containers with flammable gases or liquids can leak at low temperatures. There is a risk of an explosion! Do not store any containers with flammable materials such as, for example, spray cans, fire extinguisher refill cartridges etc in the refrigerator/freezer.
- Bottles and cans must not be placed in the freezer compartment. They can burst when the contents freeze, high carbonate content drinks can even explode! Never store lemonade, juices, beer, wine, sparkling wine etc. in the freezer compartment. Exception: high alcohol content spirits can be stored in the freezer compartment.
- Do not put ice creams or ice cubes in the mouth immediately after removal from the freezer compartment. Very cold ice can freeze to the lips or tongue and cause injury.
- Do not touch frozen food with wet hands. Your hands could freeze to the food.
- Do not operate any electrical appliances in the refrigerator/freezer (e.g. electric ice cream makers, mixers etc.).
- Before cleaning the appliance, always switch off the appliance and unplug it, or pull the house fuse or switch off the circuit breaker.
- When unplugging always pull the plug from the mains socket, do not pull on the cable.

## In case of malfunction

- If the a malfunction occurs on the appliance, please look first in the "What to do if ..." section of these instructions. If the information given there does not help, please do not perform any further repairs yourself.
- Refrigerators/freezers may only be repaired by qualified service engineers. Improper repairs can give rise to significant hazards. If your appliance needs repairing, please contact your specialist dealer or our Customer Service.

## Egregia cliente, Egregio cliente,

Prima di mettere in servizio il Vostro nuovo apparecchio, Vi preghiamo di leggere attentamente queste istruzioni per l'uso. Queste contengono informazioni importanti per un impiego sicuro, per l'installazione e per la cura dell'apparecchio.

Conservare sempre le istruzioni per l'uso per sfogliarle eventualmente in futuro. Trasmettetetele all'eventuale futuro proprietario dell'apparecchio.



Tramite il triangolo di avvertimento e/ oppure mediante segnali a parole (Avvertenza!, Precauzione!, Attenzione!), vengono messe in evidenza delle avvertenze molto importanti per la Vostra sicurezza oppure per la funzionalità del Vostro apparecchio. Pregasi osservare assolutamente.



Dopo questo segno si ottengono delle informazioni molto importanti concernenti il comando e gli impieghi pratici dell'apparecchio.



Mediante il fiore vengono contrassegnati dei consigli e delle avvertenze importanti concernenti un impiego economico e tollerabile per l'ambiente.

Per la comparsa di eventuali disturbi, nelle istruzioni per l'uso sono riportate delle avvertenze concernenti le riparazioni autonome, vedi capoverso "Che cosa fare, se...". Nel caso queste avvertenze non siano sufficienti, il nostro servizio di assistenza Vi è sempre a completa disposizione.

Stampato su carta riciclata  
– Chi pensa all'ecologia, tratta anche così ...

Malfunction	Possible Cause	Remedy
Heavy build up of frost, possibly also on the door seal.	Door seal is not air tight (possibly after changing over the hinges).	Carefully warm the leaking sections of the door seal with a hair dryer (not hotter than approx. 50 °C). At the same time shape the warmed door seal by hand such that it sits correctly.
Unusual noises.	Appliance is not level.	Readjust the feet.
	The appliance is touching the wall or other objects.	Move the appliance slightly.
	A component, e.g. a pipe, on the rear of the appliance is touching another part of the appliance or the wall.	If necessary, carefully bend the component out of the way.
The compressor does not start immediately after changing the temperature setting.	This is normal, no error has occurred.	The compressor starts after a period of time.

## Regulations, Standards, Guidelines

This appliance was designed for household use and was manufactured in accordance with the appropriate standards. The necessary measures in accordance with appliance safety legislation regulations (GSG), accident prevention regulations for refrigeration appliances (VBG 20) and the regulations of the German Society of Electrical Engineers (VDE) were observed in the manufacture of this appliance.

- (E)** The refrigerant circuit has been checked for leaks.
- This appliance is in accordance with the following EU guidelines:
- 73/23/EEG dated 19 February 1973 - low voltage guidelines.
  - 89/336/EEG dated 3 May 1989
- (including guideline change notice 92/31/EEG) - EMV guideline

## Disposal

### Appliance Packaging Information

All materials are environmentally sound! They can be dumped or burned at an incinerating plant without danger!

About the materials: The plastics can be recycled and are identified as follows:

>PE< for polyethylene, e.g. the outer covering and the bags in the interior.

>PS< for polystyrene foam, e.g. the pads, which are all free of chlorofluorocarbon.

The carton parts are made from recycled paper and should be disposed of at a waste-paper recycling collection location.

### Disposal of old Appliances

For environmental reasons, refrigeration appliances must be disposed of properly. This applies to your old appliance, and - at the end of its service life - for your new appliance as well.

**Warning!** Before disposing of old appliances make them inoperable. Remove plug from mains, sever the power cable, remove or destroy any snap or latch closures. This eliminates the danger that playing children lock themselves into the appliance (danger of suffocation!) or place themselves into other life-endangering situations.

**Disposal:**

- The appliance may not be disposed of with domestic waste or bulky refuse.
- The refrigerant circuit, especially the heat exchanger at the back of the appliance, may not be damaged.
- Information concerning collection schedules or locations can be obtained from the local disposal authorities or town hall.

## Remove transport safeguard

The appliance and the interior fittings are protected for transport.

- Pull off the adhesive tape on the left and right side of the door.



- Remove all adhesive tape and packing pieces from the interior of the appliance.

# Installation

## Installation Location

The appliance should be set up in a well ventilated, dry room.

Energy use is affected by the ambient temperature. The appliance should therefore

- not be exposed to direct sunlight;
- not be installed next to radiators, cookers or other sources of heat;
- only be installed at a location whose ambient temperature corresponds to the climate classification, for which the appliance is designed.

The climate classification can be found on the serial plate, which is located at the left on the inside of the appliance.

The following table shows which ambient temperature is correct for each climate classification: each climate classification:

Climate classification	for an ambient temperature of
SN	+10 bis +32 °C
N	+16 bis +32 °C
ST	+18 bis +38 °C
T	+18 bis +43 °C

If installation next to a source of heat is unavoidable, the following minimum clearances must be maintained at the sides of the appliance:

- for electric cookers 3 cm;
- for oil and coal fired ranges 30 cm.

If these clearances cannot be maintained a heat insulating pad is required between the cooker and the refrigeration appliance.

If the refrigeration appliance is installed next to another refrigerator or freezer a clearance of 5 cm at the sides is required, in order to prevent the formation of condensation on the outside of the appliance.

# What to do if ...

## Correcting Malfunctions

A malfunction may be caused by only a minor fault that you can rectify yourself using the following instructions. Do not perform any other work on the appliance if the following information does not provide assistance in your specific case.

**Warning!** Repairs to refrigerators/freezers may only be performed by qualified service engineers. Improper repairs can give rise to significant hazards for the user. If your appliance needs repairing, please contact your specialist dealer or our Customer Service.

Malfunction	Possible Cause	Remedy
Appliance does not work, no pilot light is illuminated.	Appliance is not switched on	Switch on the appliance.
	Mains plug is not plugged in or is loose.	Insert mains plug.
	Fuse has blown or is defective.	Check fuse, replace if necessary.
	Socket is defective.	Mains malfunctions are to be corrected by an electrician.
Green light does not light up, yellow light lights up when fast freeze function is activated, appliance is on.	Green light faulty.	Please inform your customer service
Yellow light does not light up, when fast freeze function is activated, appliance is on.	Yellow light faulty.	Please inform your customer service
Appliance cools too much.	Temperature is set too cold.	Turn the temperature regulator to a warmer setting temporarily.
The freezer temperature is not sufficient, red light lights up, temperature signal sounds	Temperature is not properly adjusted.	Please look in the "Initial Start Up" section.
	Door was open for an extended period.	Open the door only as long as necessary. Press the fast freeze switch
	A large quantity of warm food was placed in the appliance within the last 24 hours.	Press the fast freeze switch
	The appliance is near a heat source.	Please look in the "Installation location" section.
	Disturbance on the appliance	Switch on the fast freeze switch, keep the freezer closed, inform your customer service

2. Defrost the freezer compartment prior to cleaning (see "Defrosting" section).
3. Switch the appliance off and remove the plug from the mains, or switch off or turn out the circuit breaker or fuse.
4. Clean the appliance and the interior accessories with a cloth and lukewarm water. Commercially available dish washing detergents may also be used.



After cleaning wipe with fresh water and rub dry.

Accumulation of dust at the condenser increases energy consumption. For this reason carefully clean the condenser at the back of the appliance once a year with a soft brush or a vacuum cleaner.



Do not pull, move or damage any pipes and/or cables inside the cabinet.

## Switching off the appliance

If the appliance is not going to be used for an extended period:

1. Remove all deep-frozen packages as well as ice trays.
2. Switch off the appliance by turning the temperature regulator to position "0".
3. Remove the mains plug or switch off or turn out the circuit breaker or fuse.
4. Defrost freezer compartment and clean thoroughly (see section: "Cleaning and Care").
5. Leave the door open to avoid the build up of odours.



## Energy Saving Tips

- Do not install the appliance near cookers, radiators or other sources of warmth. High ambient temperatures cause longer, more frequent operation of the compressor.
- Ensure sufficient air circulation and exhaust at the appliance base and at the back wall of the appliance. Never cover air vent openings.
- Do not place warm foods into the appliance. Allow warm foods to cool first.
- Only leave door open as long as necessary.
- Do not set temperature any colder than necessary.
- Put frozen food in the fridge to defrost. The cold in the frozen food will then be used to cool the fridge.
- Keep the heat emitting condenser, the metall grille on the rear wall of your appliance, always clean.

## Your appliance needs air

For safety reasons, minimum ventilation must be as shown Fig.

Attention: keep ventilation openings clear of obstruction;

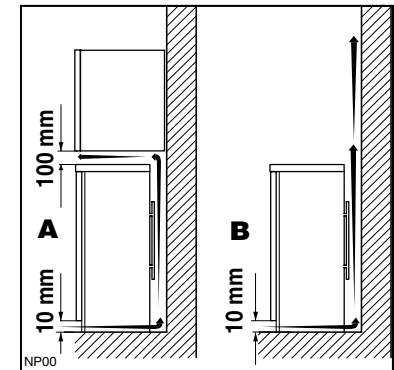

## Rear spacers

In the bag with the documentation, there are two spacers which must be fitted.

Slacken the screws and insert the spacer under the screw head, then re-tighten the screws.

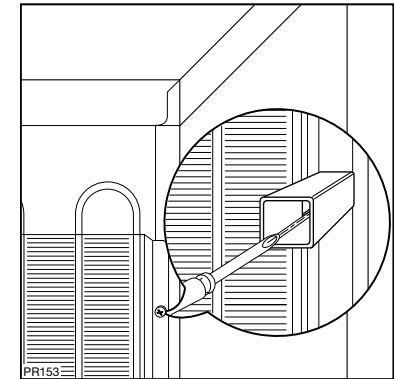

## Rehinging the door



The side at which the door opens can be changed from the right side (factory adjustment) to the left side, if the installation site requires.

**Warning!** When changing the side at which the door opens, the appliance may not be connected to the mains. Remove plug from the mains beforehand.

## Proceed as follow:

1. Remove the clip-in ventilation grille (D).
2. Remove the bottom hinge (E) by unscrewing the two fixing screws.
3. Slide the door off pin (G); unscrew pin (G) and refit it on the opposite side.
4. Remove the two plugs, to reveal the holes for the hinge pivots,

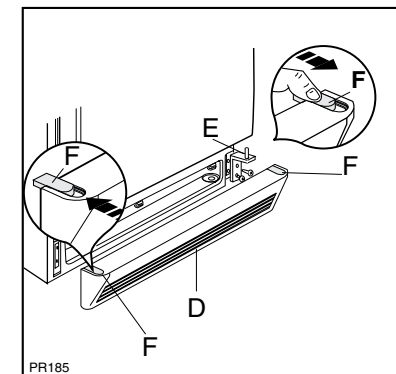



and remount them on the other side.

5. Refit the door.
6. Refit bottom hinge (E) on the opposite side, using the two screws previously removed.
7. Remove blanking cover (F) from ventilation grille (D) by pushing it in the direction of the arrow and refit it on the opposite side.
8. Refit ventilation grille (D), clipping it into place.
9. Unscrew the handle. Refit it on opposite side after having pierced the plugs with a punch. Cover the holes left open with the plugs contained in the documentation pack.

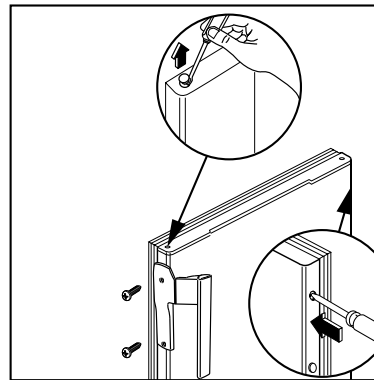
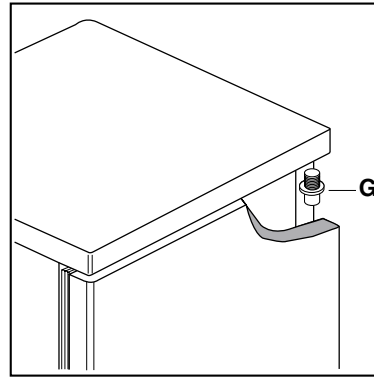

#### Attention:

After having reversed the opening direction of the doors check that all the screws are

properly tightened and that the magnetic seal adheres to the cabinet. If the ambient temperature is cold (i.e. in Winter), the gasket may not fit perfectly to the cabinet. In that case, wait for the natural fitting of the gasket or accelerate this process by heating up the part involved with a normal hair-drier.

## Electrical connection

Before initial start-up, refer to the appliance rating plate to ascertain if supply voltage and current values correspond with those of the mains at the installation location.

e.g.: AC 220 ... 240 V 50 Hz or  
220 ... 240 V~ 50 Hz

(i.e. 220 to 240 volts alternating current, 50 Hertz)

The rating plate is inside the appliance on the left.

A correctly installed, earthed socket is required for the electrical supply. The supply must have a fuse rating of at least 10 Amps.

4. Insert the plastic scraper into the recess provided under the defrost water channel and place a collecting basin under it.
5. Once defrosting is completed keep the scraper for future use;
6. Turn the thermostat knob to the required setting or replace the plug in the power socket.



#### Warning!

Never use metal tools to scrape off the frost

Do not use a mechanical device or any artificial means to speed up the thawing process other than those recommended by the manufacturer.

A temperature rise of the frozen food packs, during defrosting, may shorten their safe storage life.

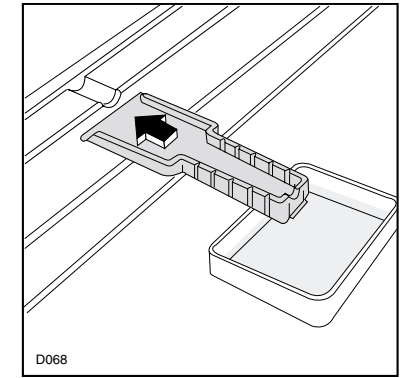

## Cleaning and Care



For hygienic reasons the appliance interior, including interior accessories, should be cleaned regularly.

#### Warning!

- The appliance may not be connected to the mains during cleaning. Danger of electrical shock! Before cleaning switch the appliance off and remove the plug from the mains, or switch off or turn out the circuit breaker or fuse.
- Never clean the appliance with a steam cleaner. Moisture could accumulate in electrical components, danger of electrical shock! Hot vapours can lead to the damage of plastic parts.
- The appliance must be dry before it is placed back into service.

#### Attention!

- Ethereal oils and organic solvents can attack plastic parts, e.g.
  - lemon juice or the juice from orange peels;
  - butyric acid;
  - cleansers which contain acetic acid.

Do not allow such substances to come into contact with appliance parts.

- Do not use any abrasive cleansers.

1. Remove frozen food and the food from the refrigerator. Wrap frozen food in several layers of newspaper. Store it in a cool place, well covered.

2. Press the fast freeze button 24 hours before introducing fresh food for freezing of fresh food. The yellow light comes on.
3. Place frozen foods in the drawers sorted by type, as far as possible.

## Preparation of Ice Cubes

1. Fill the ice cube tray 3/4 full with cold water, place it in the freezer compartment and leave to freeze.
2. To loosen the frozen cubes, either bend the ice cube tray or hold it under running water for a few seconds.

**Important!** Never try to free an ice tray that is frozen to the freezer compartment using pointed or sharp edged objects. Use the ice scraper supplied.

## Ice pack

There are two ice packs in one drawer of the freezer.

In the event of a power failure or malfunction, the ice packs will lengthen the amount of time it takes for the frozen food to become too warm by several hours. The ice packs can only fulfil this task optimally if it is placed in the uppermost drawer, at the front, above the frozen food. You can use the ice packs for cooling cold bags.

## Defrosting

The freezer compartment, however, will become progressively covered with frost. This should be removed with the special plastic scraper provided, whenever the thickness of the frost exceeds 4 mm. During this operation it is not necessary to switch off the power supply or to remove the foodstuffs.

However when the ice becomes very thick on the inner liner, complete defrosting should be carried out as follows:

1. Remove the frozen food from the freezer, wrap it in several layers of newspaper and put it in a very cool place.
2. Switch off the appliance and pull out the plug, or remove or unscrew the safety fuses.
3. Leave the freezer compartment door open.

If the socket is not accessible once the appliance is built in, the electrical installation must include suitable means of isolating the appliance from the mains (e.g. fuse, cut-out, current trip or similar with a minimum contact separation of 3 mm).

**Attention:** The mains connection cable may only be replaced by a skilled electrician. Please contact your dealer or our customer service department for repairs.

## Prior to Initial Start-Up

- Please clean the appliance interior and all accessories prior to initial start-up (see section: "Cleaning and Care").

## Operating and indicator panel

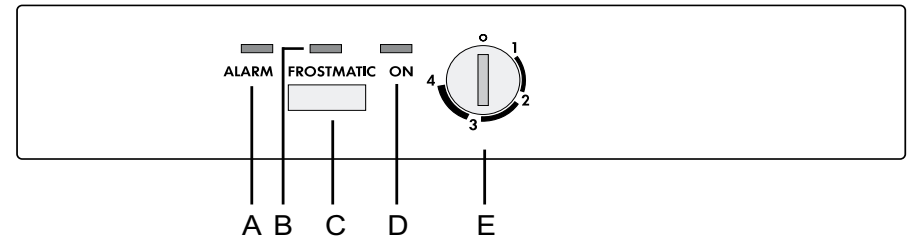

- A Alarm light (red)
- B Fast freezing light (yellow)
- C Fast freezing switch and reset sound signal alarm
- D Operating light (green)
- E Temperature regulator - ON/OFF knob

The green pilot lamp (D), which comes on when the mains voltage is available and the ON/OFF knob is pushed. Switch the temperature regulator to a number position, the refrigerating unit automatically operates by system control.

The temperature regulator (E), which can be used for continuously variable setting of the most energy saving storage temperature for your frozen food.

The optimum storage conditions occur at -18°C. The yellow pilot light (B) comes on when the switch (C) has been pushed. The refrigerating unit then operates continuously.

The red temperature pilot-lamp (A) blinks when:

- the appliance has been started up but the storage temperature has not yet been attained;
- the minimum storage temperature is no longer being maintained (fault);
- excessive amounts of fresh food are placed inside; or

**Important note:** if you operate the fast-freeze switch or adjust the temperature regulator, it may happen that your appliance's refrigeration motor does not start immediately but only after some time. This does not mean that your appliance has a fault.

## Starting up and temperature regulation

Please clean the appliance interior and all accessories prior to starting the appliance. Plug in the appliance at the mains supply.

- Turn the ON/OFF knob (E). The green lamp (D) comes on.
- Turn the temperature regulator (E) in the direction of „1“.
- To reset the sound alarm push the button (C) and the alarm light (A) blinks until the reaching of the storage temperature .
- Operate the fast-freeze switch (C). The yellow pilot lamp (B) comes on by pressing the switch (C) again .
- Only when the red lamp (A) has gone out should you reset the fast-freeze switch (C) the yellow light (B) goes out by pressing the switch (C) again.

**Setting "0":** Off.

**Setting "1":** Highest temperature, (warmest setting).

**Setting "4" (end-stop) :** Lowest temperature, (coldest setting).

The exact setting should be chosen keeping in mind that the temperature inside the appliance depends on:

- the quantity of food stored
- how often the door is opened
- ambient temperature

**Important:**

Regularly check on the red temperature pilot lamp (A) that the required storage temperature is being maintained.

## Freezing and storing frozen food

You can use your freezer for freezing fresh food yourself.

**Important!**

- The temperature in the freezer compartment must be  $-18\text{ }^{\circ}\text{C}$  or colder before freezing food.
- Please observe the freezing capacity given on the rating plate. The freezing capacity is the maximum quantity of fresh food that can be frozen within a period of 24 hours. If you wish to freeze food several days in a row, please observe a maximum capacity of only 2/3 to 3/4 of that on the rating plate. The quality of the food is best preserved when it is frozen right through to the core as quickly as possible.
- Allow warm food to cool down before freezing. The warmth will cause increased ice formation and increase the power consumption.
- Please note the maximum storage times specified by the manufacturer.
- Thawed foods which have not been processed further (cooked into meals) may not under any circumstances be frozen a second time.
- Containers with flammable gases or liquids can leak at low temperatures. There is a risk of an explosion! Do not store any containers with flammable materials such as, for example, spray cans, fire extinguisher refill cartridges etc in the refrigerator/freezer.
- Bottles and cans must not be placed in the freezer. They can burst when the contents freeze, high carbonate content drinks can even explode! Never store lemonade, juices, beer, wine, sparkling wine etc. in the freezer. Exception: high alcohol content spirits can be stored in the freezer.
- All foods must be packed air tight prior to freezing, so that they do not dry out or lose their flavour, and so that no flavour contamination of other frozen goods occurs.

**Caution!** Do not touch frozen food with wet hands. Your hands could freeze to the food.

1. Place the packed food in the drawers. Place food to be frozen As shown in figure. Unfrozen food must not touch items already frozen, otherwise the frozen food could begin to defrost.

